

Type	MRT 3050
Uitvoering	Roterend 360°
Hefhoogte	29.70 meter
Reikwijdte	25.50 meter
Hefcapaciteit	4.999 kg
Aandrijving	Dieselmotor
Eigen gewicht	22.860 kg
Rijsnelheid	50 km/u
Stempels	Hydraulisch
Max. stempelbreedte	7.10 meter
<b>Afmetingen</b>	
Lengte	7.78 meter
Breedte	2.50 meter
Hoogte	3.26 meter
Draaicircl	5.56 meter

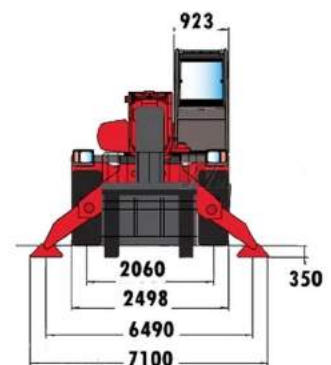

- Voorzien van grasbanden
- Diverse opzetstukken leverbaar

## WERKDIAGRAM MRT 3050 BREED GESTEMPELD

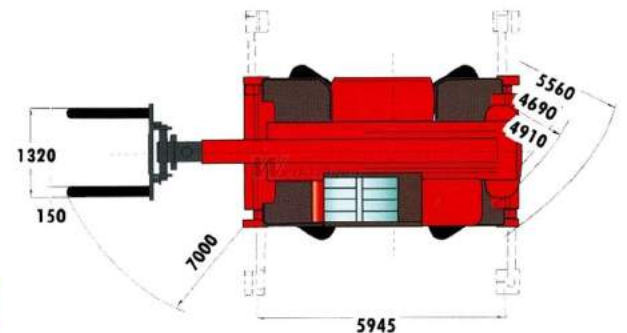
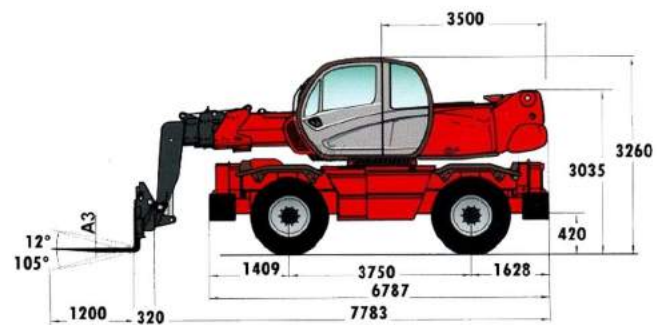
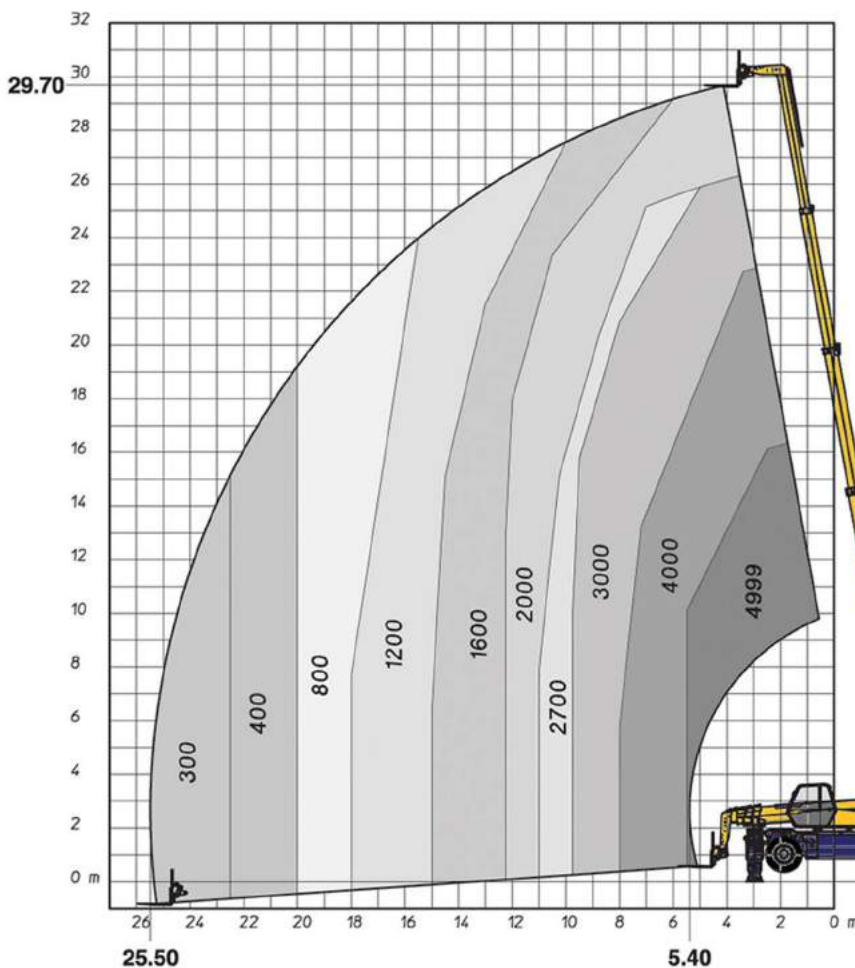

**WERKDIAGRAM  
MRT 3050  
SMAL GESTEMPELD**

